



**stein**<sup>®</sup> | NEXT LEVEL  
AUTOMATION | CONVEYOR  
TECHNOLOGY





How do I increase the economic efficiency in transport?

How can I make my production processes more flexible?

How do I make my assembly line smarter?

## NEXT LEVEL PRODUCTION

**STEIN Automation is your partner for intelligent transport in assembly and material flow. We think ahead and offer you future-proof solutions for your production processes.**

We don't just move your products from A to B, we offer you an intelligent, holistic solution that puts you in a sustainable position for the future. In doing so, we combine innovative technologies with our values of longevity, energy efficiency and conservation of resources that we have lived by for decades.

The STEIN shuttle and transfer systems form a perfect, harmonious unit together with the STEIN control system. This gives you a system that is optimally tailored to your requirements and, thanks to standardized interfaces, implements networked production to perfection.

We bring production to the STEIN-level.

Jürgen Noailles



'STEIN Automation is a forward-thinking company on a growth path. Thanks to the solid foundation of the company, the passion and the innovative strength of our employees, we inspire our customers with solutions that are unparalleled in the market.'

Jürgen Noailles, Managing Director



# INNOVATION FOR THE PRODUCTION OF TOMORROW



**1992**  
STEIN delivers the first networked assembly lines for Industry 4.0

Market launch of **stein** | 300

Intelligent transfer system for weights up to 25 kg (55 lbs)



**1973**  
First loading and discharging units built for processing machines



**2013**  
STEIN Ergonomics Concept with height-adjustable workstations

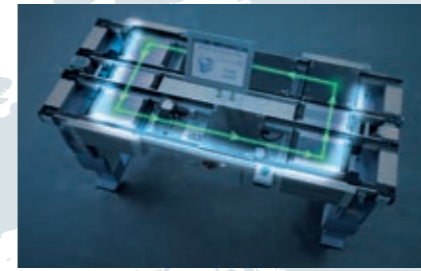

**2019**  
Market launch of **stein** | 300e  
Purely electric transfer system for weights up to 25 kg (55 lbs)

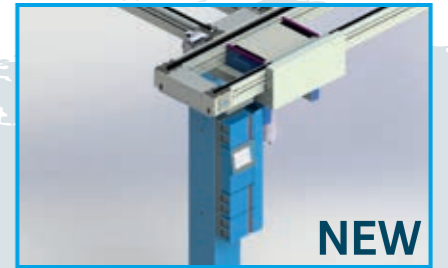

**2022**  
Market launch of **stein** | C5G  
The next level of intelligent assembly logistics



**2022**  
Market launch of **stein** | 400  
Intelligent transfer system for weights up to 80 kg (176 lbs)



**2008**  
Market launch of **SOFTMOVE**.  
TRANSPORT MADE BY STEIN  
Innovative control technology for smooth, quiet & energy-efficient transport



**1987**  
First double-belt conveyor system built under license

**2020**  
**Indutrade** becomes a new partner

**2022**  
3900 STEIN-systems in operation worldwide

**2023**  
Market launch of **stein** | link  
Battery operated shuttle system for weights up to 80 kg (176 lbs), transport speed 50 m/min





# FROM THE COMPONENT TO THE INDIVIDUAL SYSTEM

The benefits of the modular design of the STEIN system are obvious: it is easy to configure, it allows a free combination of manual and automatic stations and, if necessary, it can be converted in a very short time. The modular component system allows each customer to plan in detail how their system should look. The finished STEIN system is always oriented towards production and the work steps required there, not the other way around. Based on our many years of experience, we can help with planning and design and complement the customer's ideas with our advice.

As soon as the overall system has been finalized, prompt commissioning becomes a key factor. Thanks to a high level of vertical integration and local supplier relationships, STEIN impresses with short delivery times and installs the conveyor system directly on the customer's production site after completion. The overall service also includes commissioning and user training.

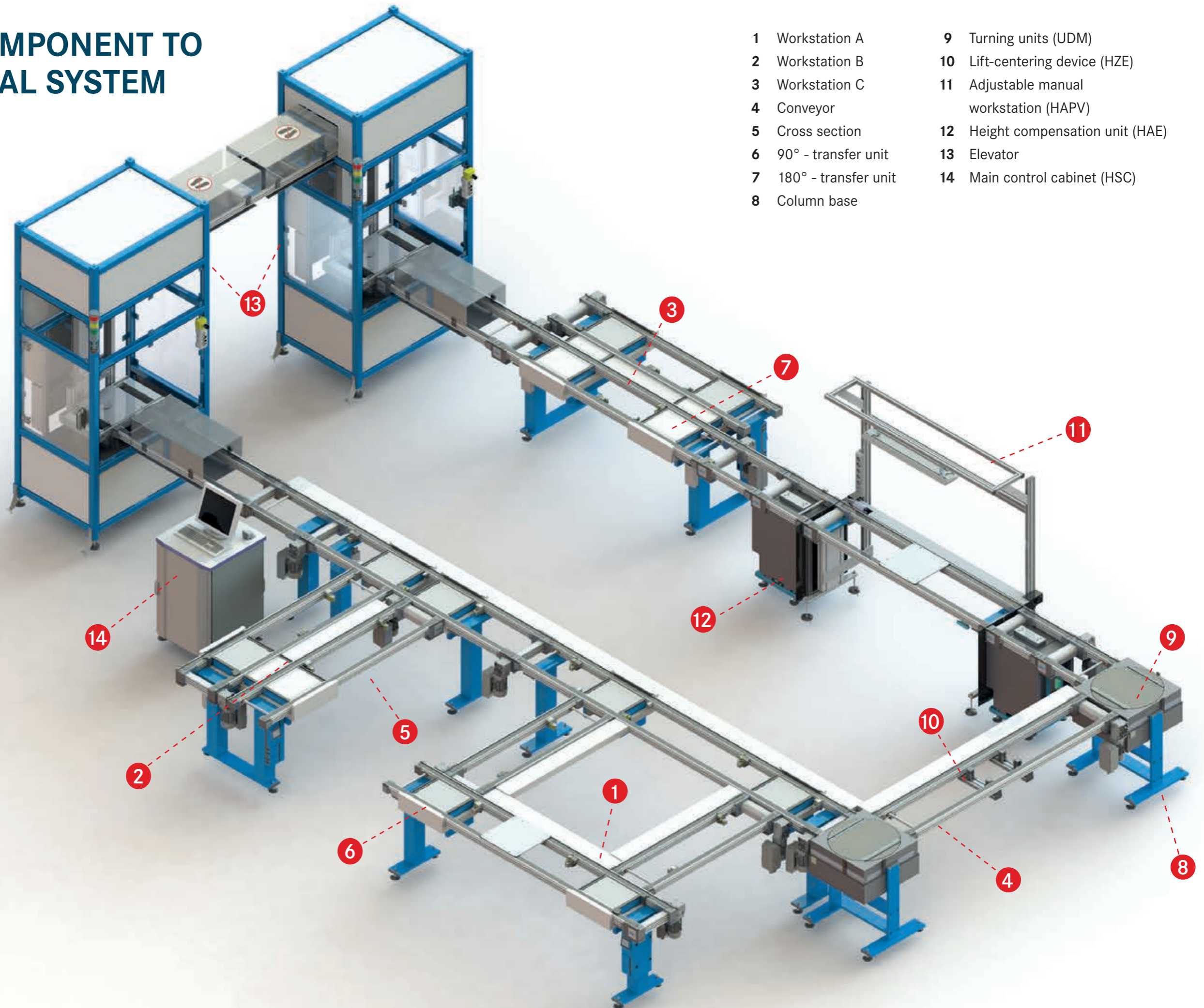

- |   |                      |    |                                      |
|---|----------------------|----|--------------------------------------|
| 1 | Workstation A        | 9  | Turning units (UDM)                  |
| 2 | Workstation B        | 10 | Lift-centering device (HZE)          |
| 3 | Workstation C        | 11 | Adjustable manual workstation (HAPV) |
| 4 | Conveyor             | 12 | Height compensation unit (HAE)       |
| 5 | Cross section        | 13 | Elevator                             |
| 6 | 90° - transfer unit  | 14 | Main control cabinet (HSC)           |
| 7 | 180° - transfer unit |    |                                      |
| 8 | Column base          |    |                                      |



# STEIN EXPANSION STAGES

## CARE-FREE IN EVERY ASPECT WITH STEIN

With STEIN Automation you get the complete package for the transport of your products in the assembly process and material flow. With our turnkey solution, you not only get a fully assembled STEIN transfer system, but also a control and logistics system for the system configured to your needs, including our innovative STEIN SOFTMOVE technology. In addition, our excellent installation team will set up the entire system at your premises in the shortest possible time, commission it and train your employees.

If you want to use a STEIN transfer system with your own control system, we can also supply you with components only - with or without assembly by our team.

With STEIN, you can be sure that we will focus entirely on your needs and that you will receive a system that will take your production to the next level.



### FULL SERVICE

### COMPONENTS

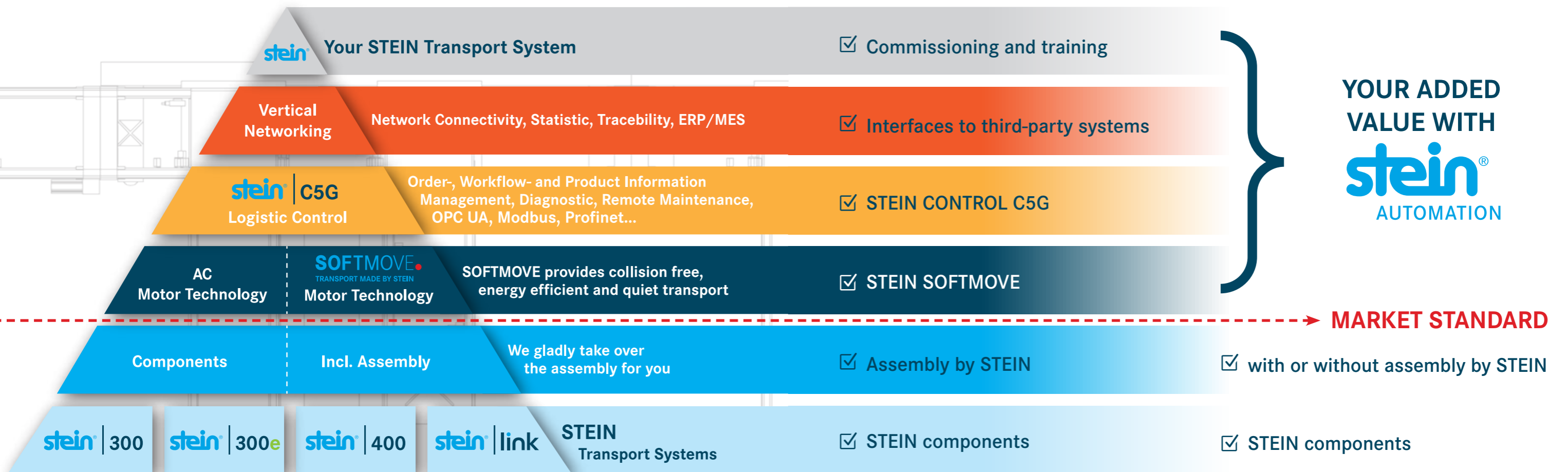

# STEIN PRODUCT OVERVIEW:

## TRANSFER SYSTEMS

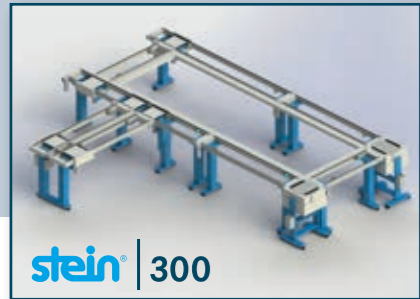

- Pallet size > 160 mm (6.2")
- Weight up to 25 kg (55 lbs)
- Freely scalable/pneumatic

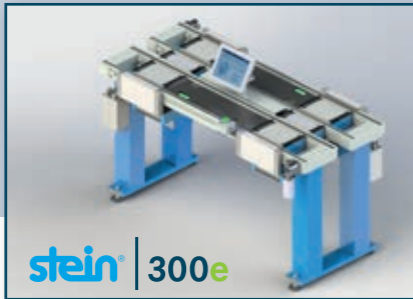

- Pallet size > 160 mm (6.2")
- Weight up to 25 kg (55 lbs)
- Freely scalable/electric

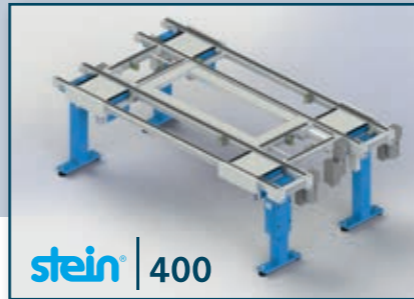

- Pallet size > 240 mm (9.4")
- Weight up to 80 kg (176 lbs)
- Freely scalable

### stein | LEAN

- More productivity per space
- Shorter through-put time
- Higher flexibility

## SHUTTLE SYSTEM



- Flexible loading surface
- Max. load capacity/shuttle: 80kg (176 lbs)

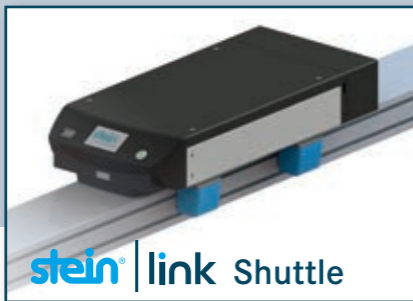

- Transport speed: max. 50 m/min
- Exchangeable battery: up to 10,000 mAh

## CONTROL

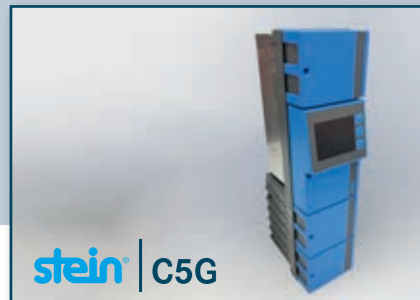

- 5 Anybus interface slots
- Order Management, diagnostics,...
- Easy to configure
- Industry 4.0 capable

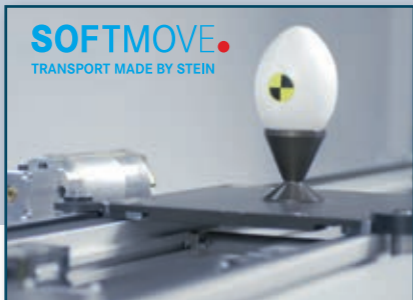

- Economical, reduces energy consumption and system noise
- Prevents pallets from colliding hard, less dirt

\* Other sizes on request

# STEP UP TO THE NEXT LEVEL WITH STEIN

## ROLLER CASSETTES



Underneath the flat belts:

- Extremely low wear and abrasion
- Very durable belts: maintenance-free, high system availability, low operating costs

## SHORT DELIVERY TIMES



- Components are delivered within 4 to 6 weeks
- Together with STEIN C5G, we supply complete solutions in 12 to 14 weeks

## COMPLETELY COLLISION-FREE



Thanks to the innovative STEIN SOFTMOVE technology:

- Smooth, collision-free transport up to 80kg transport weight
- Safety for sensitive transport goods, fewer scrap parts
- Significant noise reduction in production
- Low wear, increased product life and thus lower operating and maintenance costs

## CARE-FREE IN EVERY ASPECT



- Total package perfectly tailored to your processes
- Having everything from a single source ensures optimum processes, high availability and short delivery times
- All-round support from planning to commissioning and beyond for the entire lifetime of your production system

## SUSTAINABILITY



- Lean systems require minimal production space and resources
- Long time component and software availability, backward compatibility
- Sustainable and future-proof thanks to durability and high energy efficiency
- Extremely flexible and reusable modules reduce the effort required for retrofitting the production

## ENERGY EFFICIENCY



- Up to 70% higher energy efficiency
- Up to 70% savings in electricity
- Up to 70% lower CO<sub>2</sub> emissions





# LOGISTICS FOR THE INDUSTRY OF TOMORROW

**STEIN C5G is the intelligent control system for STEIN transfer systems and the associated production processes and sequences. STEIN C5G comprises both the STEIN PLC control and the STEIN logistics including all software applications.**

**C5G is a proprietary development of STEIN Automation, which has been continuously developed and perfected over more than 30 years. Experience from countless successful customer projects has been incorporated. Since 2022, the fifth generation of STEIN control and logistics has been on the market, called CONTROL 5th GENERATION (C5G).**

**With the latest generation of control and logistics, STEIN has not only strengthened the basis on standardized protocols and interfaces even more, but also raised functionality and performance to the next level of modern automation. The result is a high-performance control and production logistics system that will bring your production to the STEIN-level.**

**+** In production, every second counts - which is precisely why **control and mechanics** must be perfectly coordinated.

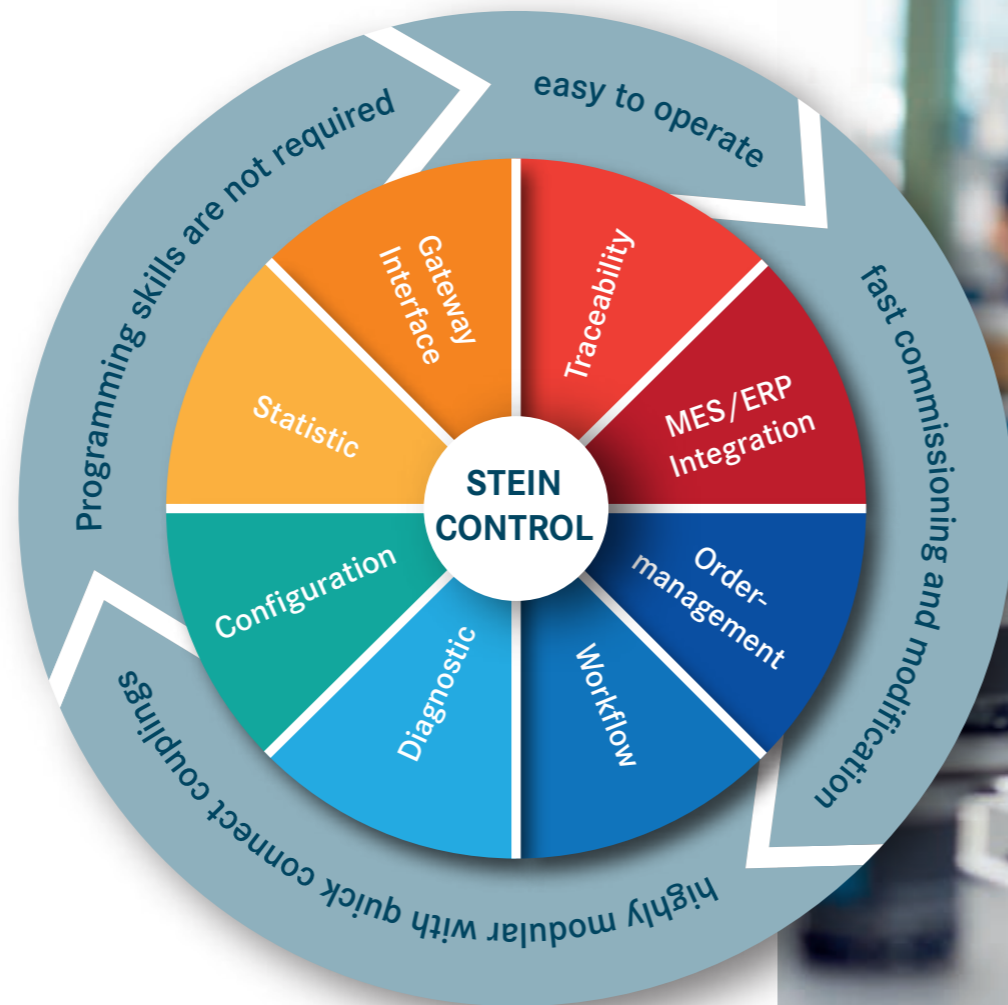

## **MODULAR AND FLEXIBLE – IN MECHANICS AND SOFTWARE**

C5G was developed with the objective of "configuring instead of programming". Accordingly, C5G is consistently structured in such a way that production sequences and processes can be easily configured, and no complex programming is necessary.

This gives you the following advantages:

- Changes to the production line and processes can be implemented quickly and easily at any time
- System operators can make small changes independently
- Control and logistics can be adapted to the individual requirements of each customer

## **THE PERFECT, HARMONIOUS UNITY**

C5G is an innovative, proprietary development by STEIN and thus perfectly matched to STEIN transfer systems. The system, control and software form one unit. Although C5G was developed specifically by STEIN, it is based on standardized programming languages and open communication protocols.

This gives you the following advantages:

- Harmonious, smooth processes ensure maximum reliability
- C5G is always kept up to date with the latest developments
- Open for interface communication
- Large STEIN support team in the background

## **FROM HIGH VOLUME TO BATCH SIZE 1**

C5G includes a sophisticated logistics package that covers the entire spectrum from high-volume production to mixed operation and batch size 1. In the process, STEIN logistics has extensive database functionality that enables seamless documentation and quality monitoring of each individual production step and parameter for each individual product.

This gives you the following advantages:

- Extensive function package for your exact requirement
- Smooth Production from batch size 1
- Seamless monitoring of all parameters and production steps



**+** **Intelligent pallets** transmit the unique identity of each workpiece to the relative station.

**+** An **easy-to-configure workflow** ensures safe transport.

### **STEIN C5G TECHNICAL DATA:**

- Based on Linux OS, Codesys, structured text (IEC 61131-3)
- 5 Anybus interface slots per PLC control for Modbus, Profinet, EtherCAT, EtherNet/IP
- OPC-UA interface
- ASi-interface for communication with stoppers, switches, etc.
- RFID system for identification and position recognition of the individual pallets
- Sophisticated visualization (order management, diagnostics with live monitoring, configuration, workflow management, user administration)





Over 30 years of experience with more than 3900 individual customer systems have gone into perfecting STEIN 300. As a result, today STEIN 300 is an optimally coordinated transfer system consisting of an extensive portfolio of sub-assemblies with which the most diverse production processes can be implemented.

Thanks to the roller cassettes under the flat belt, abrasion and wear are reduced to a minimum, making STEIN 300 maintenance-free and extremely durable. The consistent modular design of STEIN 300 makes it particularly flexible. Both the initial installation and subsequent conversions can be implemented easily and in a short time. And this not only mechanically, but also in the software. STEIN C5G is perfectly matched to STEIN 300 and thus forms the ideal solution for your individual requirements. And thanks to the integrated Softmove technology, your products are not only transported particularly gently and quietly, but also extremely energy-efficient.

**TECHNICAL DATA:**

- Pallet sizes: from 160 mm x 160 mm (6.3 x 6.3 inches), freely scalable
- Max. total weight of pallet: 25 kg (55lb)  
Accumulated load: max. 75 kg
- Conveyor speed: with an EC motor: adjustable from 3 to 21 m/min  
with an AC motor: 6.9 / 9.1/13.7 or 18.3 m/min
- Conveyor length: from 350 to 3,000 mm, freely scalable (please ask about additional sizes)



In addition to intelligent control and networking, STEIN is also driving mechanical innovations. Ergonomics play a very important role here. With our systems, operators can freely decide whether they want to work sitting or standing. The height of the conveyor belt automatically adapts to the requirements.

**SOFTMOVE – QUIET**

The gentle drive of the motors dramatically reduces noise. Pallets do not bump against each other. Belts do not wear through. The result is a quiet, energy-efficient transfer system, which is good for the health of your employees.

**GATE ELEMENT – CONVENIENT**

Free access to closed internal spaces in the system allows technicians to work in a relaxed and more successful way.

**DISPLAY TERMINAL – INFORMATIVE**

The product communicates with the operator. This supports the working process directly, especially since this function is also available as a navigator.

**STEIN C5G – FAST**

Individual orders and entire production schedules can be created by the click of a mouse. This allows our customers to configure their processes very easily without having to do any programming.

**HEIGHT-ADJUSTABLE MANUAL WORKSTATIONS – ERGONOMIC**

Everyone is unique and has their own ideal working height. With STEIN, operators are free to choose the operating height, allowing them to stay relaxed to provide the best performance.

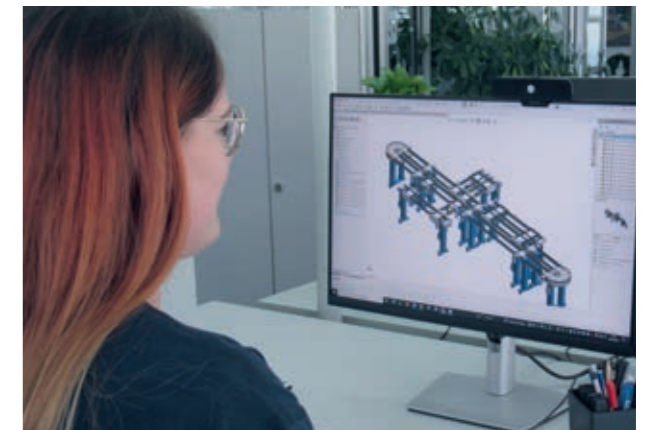

Workpieces are moved gently and quietly with Softmove

Flexible working heights





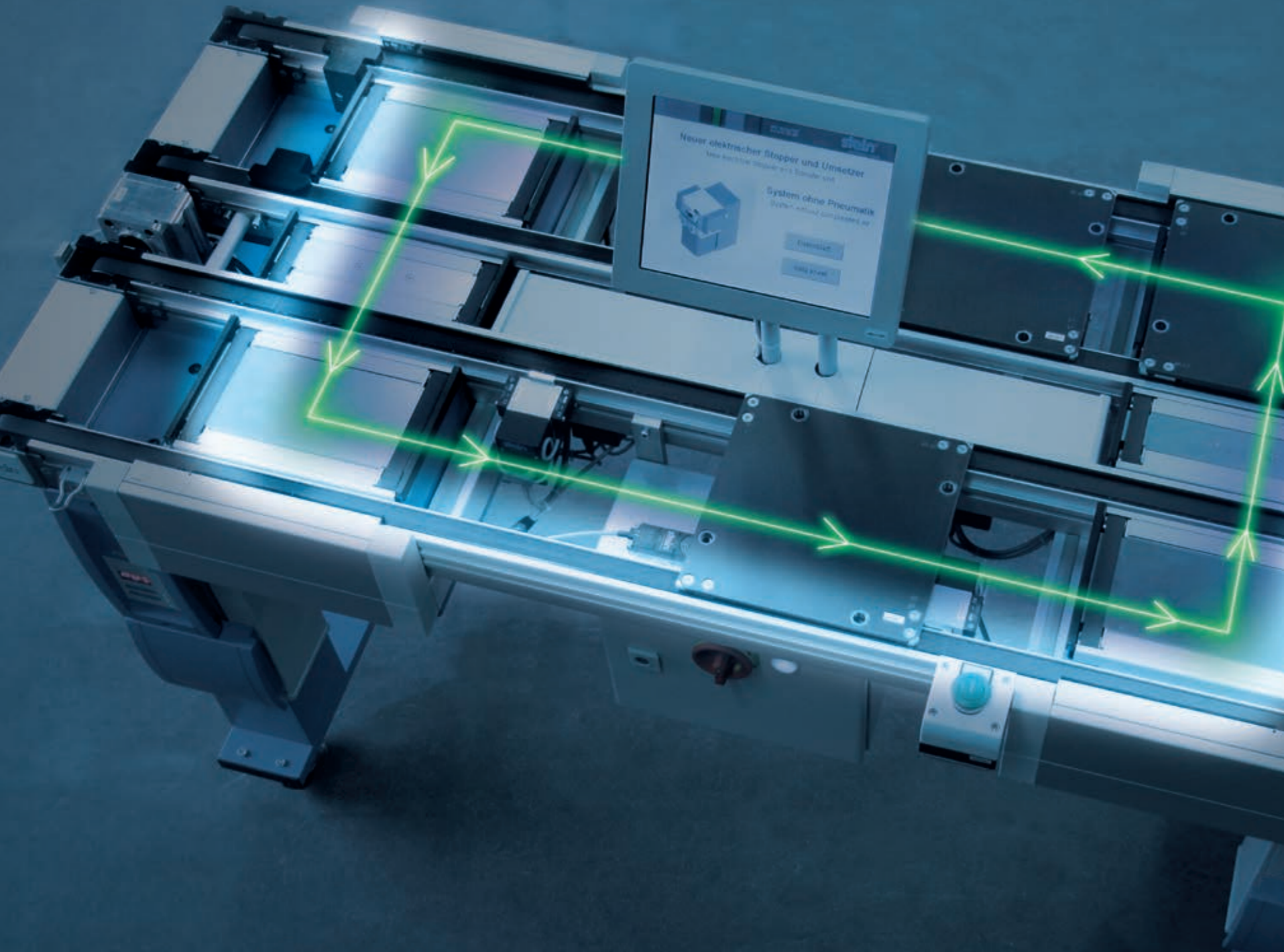

STEIN supports the trend towards electrification with the purely electric version of the 300 system - STEIN 300e. Instead of pneumatics, the stoppers, transfer units or centering devices are controlled via electric drives. This is particularly a big advantage for cleanroom applications. As a side benefit, STEIN 300e is even more energy-efficient than STEIN 300 already is.

#### USE IN CLEANROOMS

By eliminating pneumatics, STEIN 300e results in even less particulate and air turbulence, making this system ideal for use in cleanrooms. Depending on the application, STEIN 300 transfer systems are certified for ISO class 6 and 7 cleanrooms.

#### HIGHEST ENERGY EFFICIENCY

STEIN SOFTMOVE technology makes STEIN transfer systems up to 70% more energy efficient than comparable systems. The fact that STEIN 300e does not require the energy-intensive pneumatics means that an additional increase in efficiency can also be achieved.

#### INDEPENDENCE

STEIN 300e is independent of a compressed air supply, which allows it to be used with its fully comprehensive functionalities in areas where air is not available. This makes STEIN 300e a flexible solution for your individual requirements.

#### TECHNICAL DATA:

- Pallet sizes: 160 x 160 mm - 400 x 400 mm, (6.3 x 6.3 inch - 15.75 x 15.75 inch) freely scalable, other sizes on request
- Max. total weight of pallet: 25 kg (55 lb)  
Accumulated load / E-stopper: max. 3 pallets
- Transport speed: max. 21 m /min
- Power supply: 24 V DC
- Current consumption  
Standby current for E-stopper, transfer unit < 0.1 A  
Peak-current: E-stopper 1.0 A, transfer unit 2.0 A
- Stroke length:  
E-stopper 6 mm (0.24 inch)  
transfer unit 16 mm (0.63 inch)
- Lifting time: E-Stopper 0,22 s  
Transfer unit 0,4 s





STEIN 400 transports large workpieces weighing up to 80 kg (176 lbs) effortlessly and safely through the production process. Thanks to the innovative STEIN SOFTMOVE technology, even these heavy weights are transported collision-free, quietly and particularly gently.



Easy to get off the ground with up to **80 kg (176 lbs)**

#### MAINTENANCE-FREE AND DURABLE

Smooth, fast and jam-free transport is made possible by intelligent EC motors, and the pallets themselves move on ball-bearing rollers underneath the belts, so that their heavy weight is not a disadvantage for them. This makes STEIN 400 particularly durable and maintenance-free with low wear.

#### EFFICIENT FOR HEAVY PRODUCTS

Thanks to STEIN SOFTMOVE technology, the pallets stop behind each other gently and without collision, thus preventing wear, vibration and noise despite the workpieces weighing up to 80 kg. In addition, STEIN 400 is particularly energy-efficient and economical thanks to SOFTMOVE.

#### SLIM AND ROBUST

Despite its strength and robustness, STEIN 400 has a very slim design and, thanks to grid-free scalability, requires very little space and efficiently makes the best use of the available floorspace. In addition, different products in different sizes can be transported simultaneously on one pallet.

#### TECHNICAL DATA:

- Pallet sizes: 240 mm x 240 mm – 1500 mm x 1500 mm, freely scalable
- Max. total weight of pallet: 80 kg (176 lbs)  
Accumulated load: max. 240 kg (529 lbs)
- Transport speed: max. 30 m/min
- Conveyor length: from 400 to 5,000 mm, freely scalable (please ask about additional sizes)

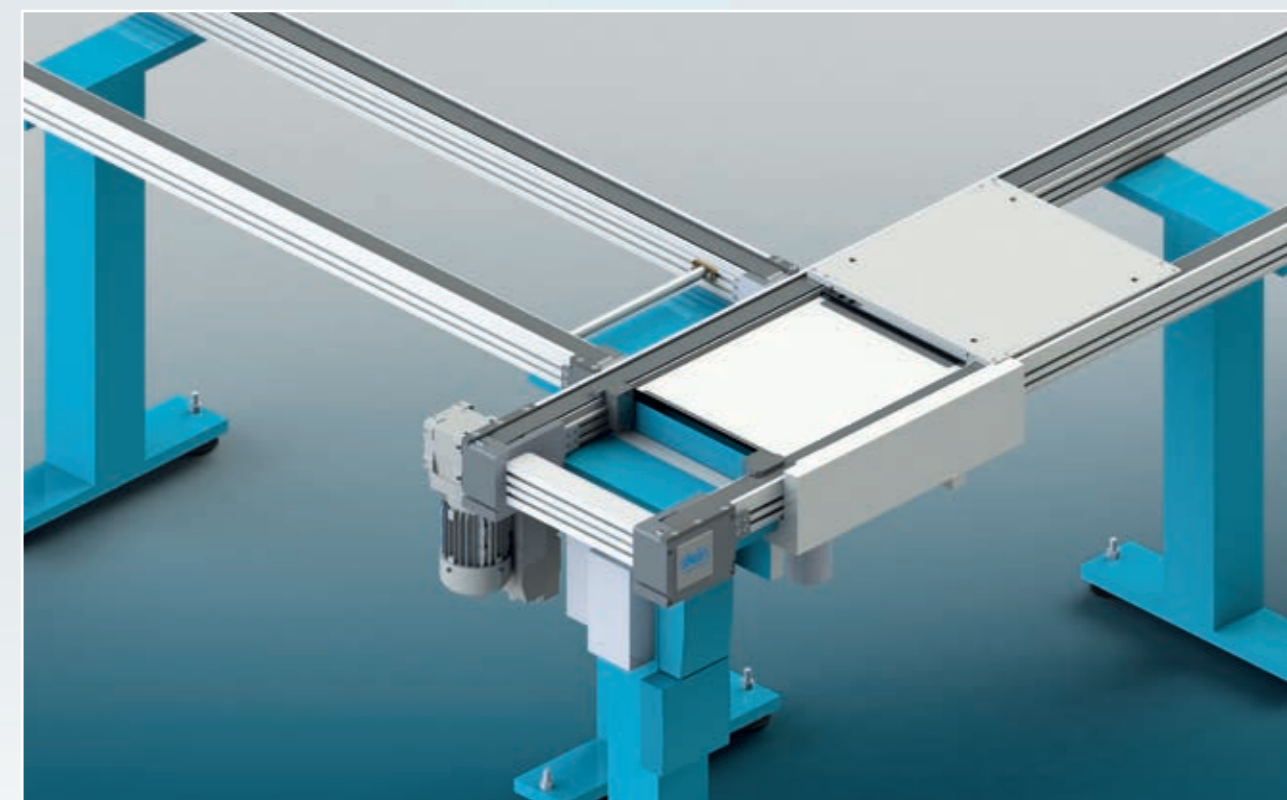
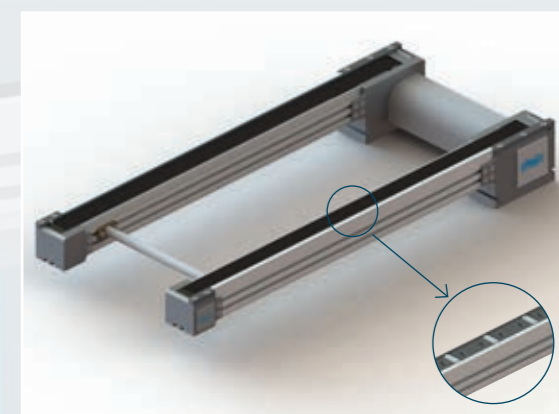



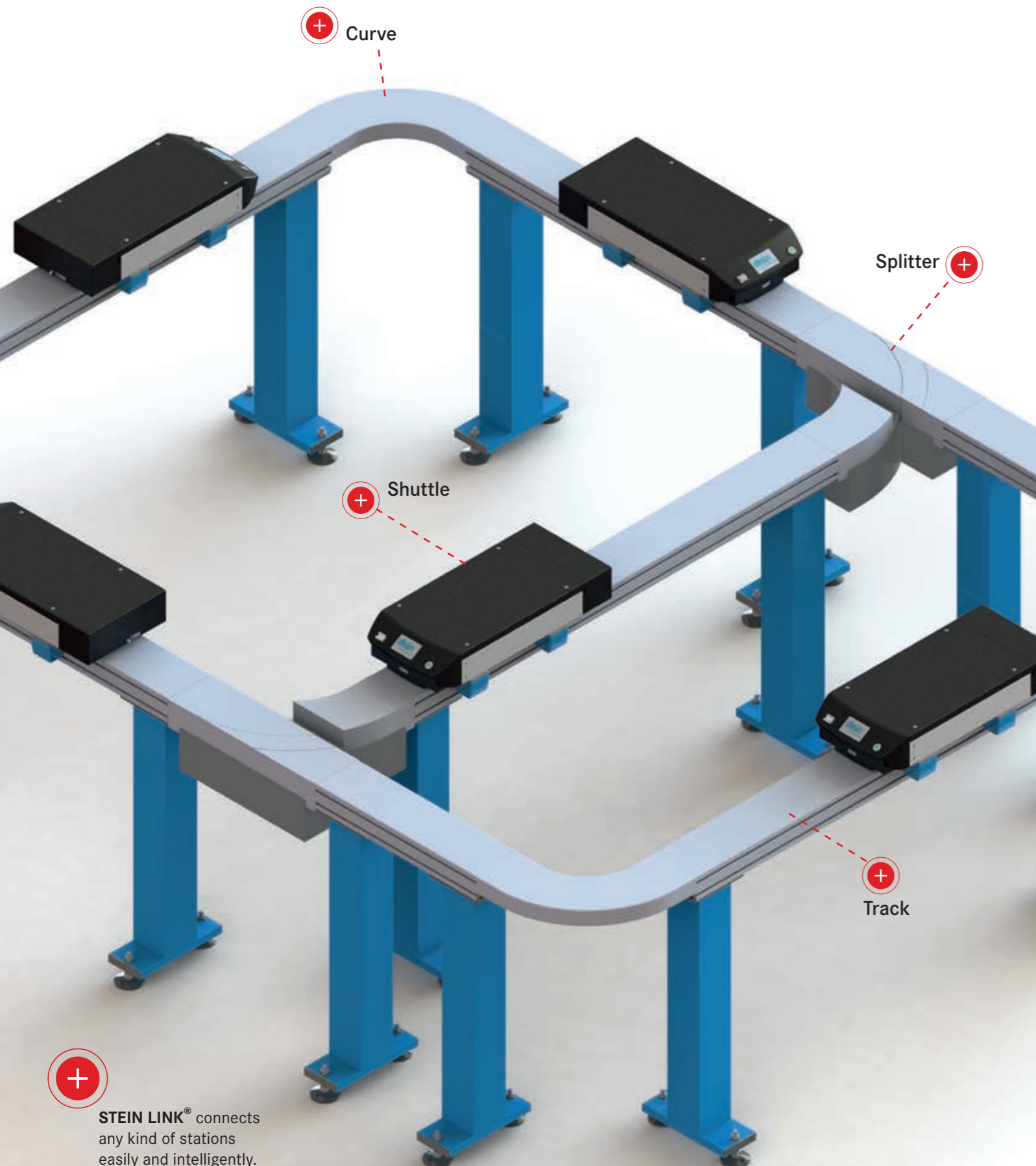

STEIN LINK® connects any kind of stations easily and intelligently.

**BEYOND TRANSFER**

The STEIN LINK® shuttle system is the logical extension of the STEIN transfer systems. It combines the assembly processes in the transfer system with internal transport. STEIN LINK® is perfectly suited to cover long distances - on the floor or under the ceiling to save floor-space. It can transport a wide variety of products on the pallet or as bulk material in transport boxes.

**BATTERY POWERED**

Each STEIN LINK® Shuttle has an easily exchangeable battery, which can be easily changed manually or fully automatically. This results in several advantages for the overall system. On the one hand, the track can be kept simple and cost-effective, as no complex electrical wiring is required. Secondly, the charging time does not affect the cycle time and availability of the shuttles. In addition, this makes the overall system extremely reliable with low maintenance.

**STABLE AND SHOCKPROOF**

The STEIN LINK® track is extremely robust and stable, so that the shuttles can drive on it without the risk of tipping over and can reliably transport even large products from A to B. Thanks to intelligent sensor technology, the shuttles independently detect obstacles of any kind and brake gently. This ensures that your sensitive products are transported gently and without impact.

**INTELLIGENT NETWORK**

The STEIN LINK® Shuttles can communicate with each other decentrally, with sub-assemblies such as splitters or collectors, and centrally with the higher-level control system. This enables fast communication adapted to the situation. Thanks to intelligent workflow and order management, the shuttles reach their destination quickly and reliably. In addition, communication with third parties such as an ERP system is possible via the central control system.



**TECHNICAL DATA:**

- Shuttle dimensions L x W x H: 661 mm x 292 mm x 178 mm
- Flexible loading surface: Pallet size, transport box, product holder (dimensions freely scalable)
- Max. load capacity per shuttle: 80 kg (176 lbs)
- Transport speed: max. 50 m/min
- Acceleration: up to 1m/sec<sup>2</sup>
- Exchangeable battery: up to 10,000 mAh
- 24 V power supply on the shuttle for active accessories (conveyor belt, tilting unit, etc.)

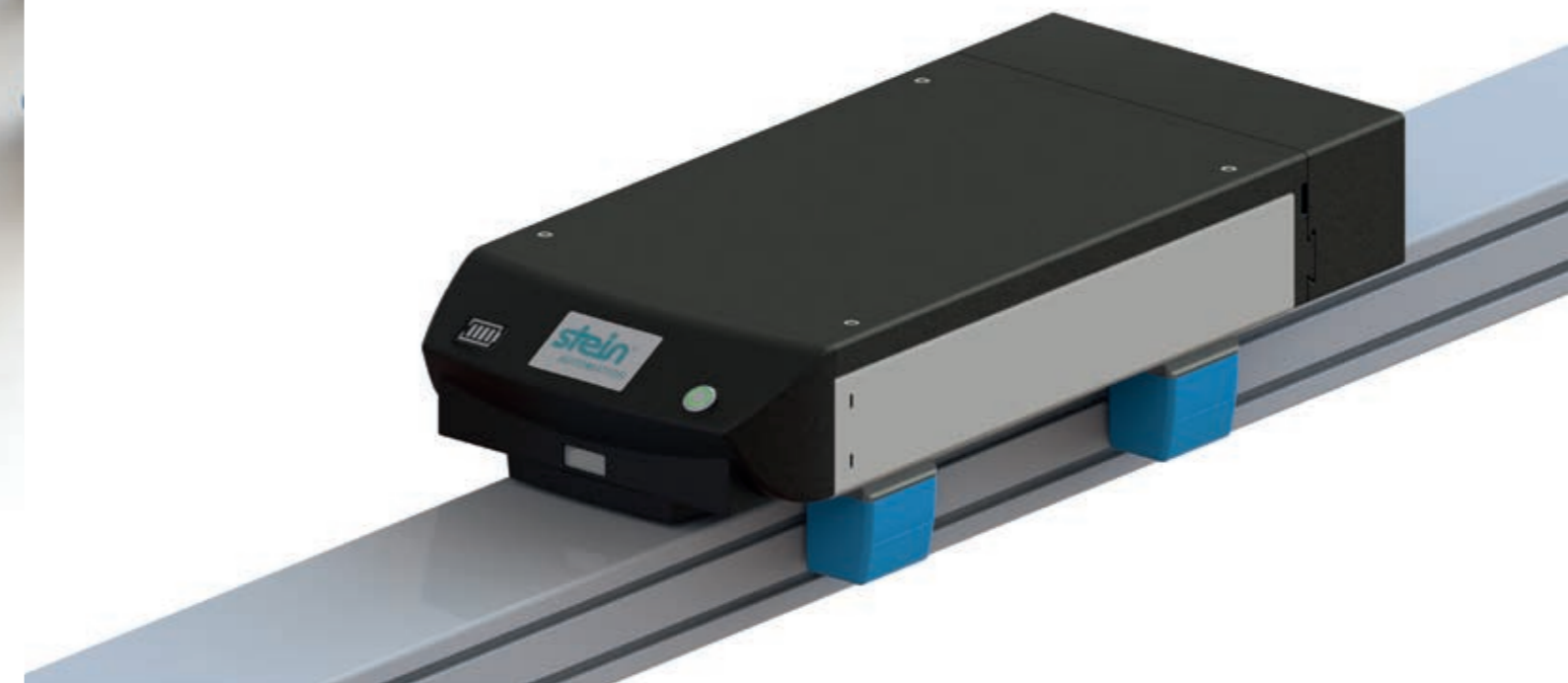



## STEIN SOFTMOVE: THE FIVE STRENGTHS OF SOFTMOVE AT A GLANCE

reduces energy consumption up to 70%	▶ enormous, long-term savings in energy costs and CO <sub>2</sub> emissions
prevents pallets from colliding hard	▶ gentle on your product (greater efficiency, more good parts) and increases the longevity of the transfer system
reduces wear and tear	▶ longer system service life, lower maintenance costs, higher system availability, greater output
less dirt	▶ improved work conditions, less maintenance, suitable for clean room
reduces system noise	▶ quieter production, fewer employees sick, improved quality at manual workstations

## EXTREMELY SOFT TRANSPORT WITH THE GREATEST EFFICIENCY

In production operations, speed is of the essence. To ensure that pallets never collide hard despite travelling at high speeds and in large volumes, STEIN has developed SOFTMOVE technology. It enables the gentlest possible transport for sensitive products while reducing wear, contamination, power consumption and noise in the system.

This saves you time, energy and therefore money. We are proud to say that only STEIN has so successfully implemented gentle and efficient transport with SOFTMOVE. With SOFTMOVE, STEIN has set new standards for handling delicate workpieces.

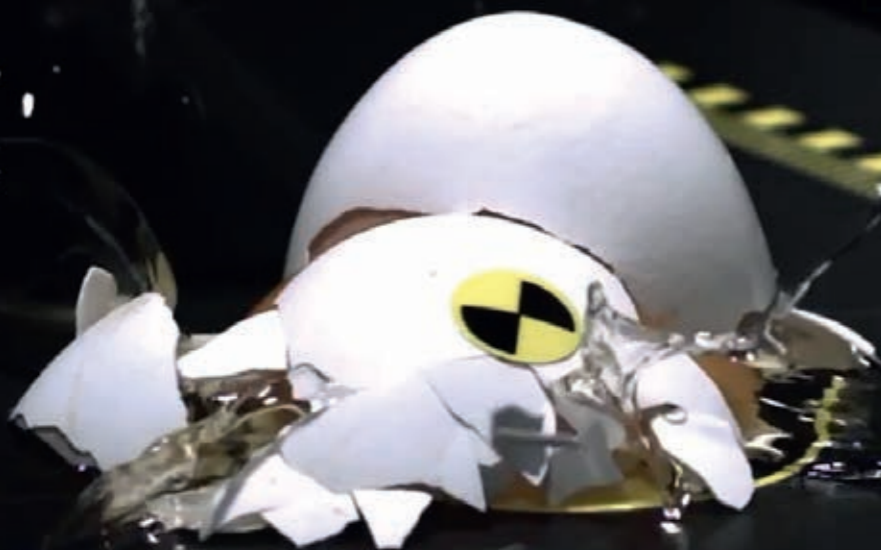

**SOFTMOVE.**  
TRANSPORT MADE BY STEIN

### TRANSPORT WITH CARE



### REDUCE WEAR



### SAVE ENERGY



### HOW SOFTMOVE WORKS

Since STEIN C5G is able to identify the exact position of each pallet, the conveyor drive motors can be programmed to ensure that there are no hard collisions and to prevent them from running when it is not necessary. The intelligent system reduces the speed of the pallet before it makes contact with the stopper latch and stops it gently. If the conveyor notices that there is no need for further transport, it automatically switches off.

### CLEANLY TRANSFERRED

By preventing collisions and shutting down the motors, SOFTMOVE minimizes wear and contamination on the transfer system. This extends the longevity of the system enormously and at the same time reduces maintenance and the need for spare parts. For you, this means higher system availability and a significant reduction in operating costs. At the same time, the reduction in contamination and noise emissions improves working conditions for your employees.

### HIGHEST ENERGY EFFICIENCY

By selectively switching off the motors at the conveyor, an efficiency increase in energy consumption of up to 70 % can be achieved. This not only lowers the operating costs of the transfer system, but also reduces CO<sub>2</sub> emissions to the same extent.

### SUSTAINABLE

SOFTMOVE makes STEIN transfer systems particularly sustainable. Due to the enormous reduction in energy consumption and the reduction in wear, the ecological footprint of STEIN systems is significantly smaller than that of comparable systems. In addition, SOFTMOVE ensures a more socially sustainable system with improved working conditions due to lower pollution and noise emissions. The high system availability, low operating costs and durability make STEIN transfer systems a sustainable investment in your future.



# THE PEOPLE BEHIND THE SOLUTIONS

At STEIN, we don't just help each other with our work – we work hand in hand. This is important to us because it allows new ideas and inspiration to flourish and benefit everyone. We respect every employee and their work and this is reflected in the way we deal with each other.

One thought is key for us: at STEIN, our employees don't only work for a company; they are part of the company. Only then each individual will be happy to contribute to the greater whole through independent work, which we encourage and value.

### MASTERFUL SOLUTIONS

Even daily work can be improved. Lots of ideas for improvement come from our employees.

### TEAMWORK

At STEIN, working together is not just a method but a conviction.

### DIRECT CUSTOMER CONTACT

Experience and service go hand in hand with us: 80 % of our employees communicate directly with customers.

### LEARNING IS PART OF WORKING

STEIN takes on apprentices in the company every year, thus investing in the future.



At STEIN, your employees take center stage

Each transfer system is **examined thoroughly** before delivery.



Quick and easy change of modules



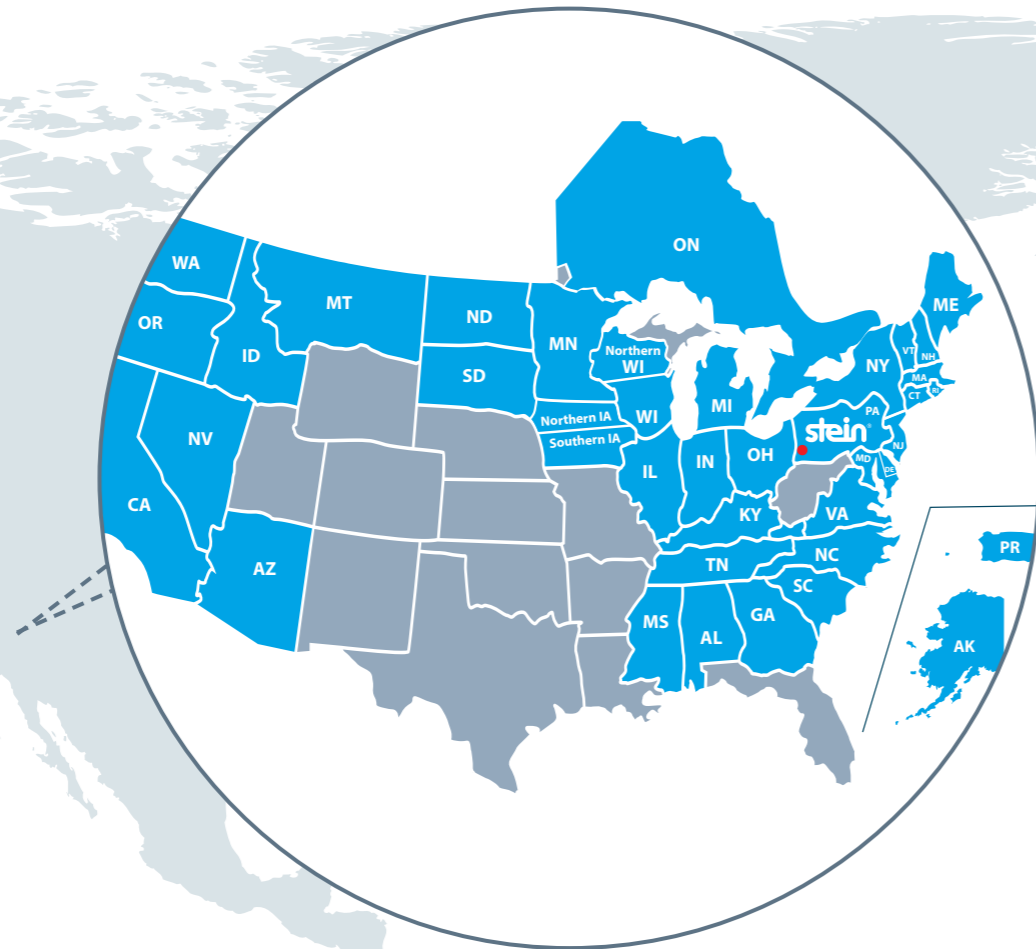

It is important to us that you receive the **best possible support** in addition to our high-quality products..

## STEIN AROUND THE WORLD

**If we merely sold products to our customers, that would be a business – not a partnership. That’s why long-term, honest and constructive relationships with our customers are very important to us.**

Customers can – and do – approach us at any time with new tasks and questions. Last but not least, it is a valuable opportunity for us to learn and develop new skills together with our customers.

Our service strategy helps us in developing customer relationships: our customers’ production take absolute priority. Online diagnostics and remote maintenance are tools which enable us to be close enough to provide help and support quickly at any time, even for customers who are far away.

We take pleasure in every new customer and at the same time take pride in having a large number of regular and existing customers who have been successfully using and valuing our systems and their collaboration with STEIN for many years.

### EXCERPT FROM OUR CUSTOMER REFERENCES:



**AUTOMOTIVE**

KIEKERT  
MAGNA MIRRORS  
CONTINENTAL  
SBS  
MAHLE



**HOUSEHOLD EQUIPMENT**

VORWERK  
IMPERIAL  
E.G.O.  
BKS  
EMSA



**TOYS AND LEISURE**

ATOMIC  
PLAYMOBIL  
EHEIM



**MEDICAL**

B | BRAUN  
CERAMTEC  
BAXTER



**PROPULSION TECHNOLOGY**

EBM-PAPST  
AMK  
SEW



**ELECTRICAL ENGINEERING**

FESTO  
HILTI  
WERMA  
ELSTER





**stein**<sup>®</sup> | NEXT LEVEL  
AUTOMATION | CONVEYOR  
TECHNOLOGY

**STEIN Automation GmbH & Co. KG**  
**Headquarters GERMANY**  
Johann-Liesenberger-Str. 7  
78078 Niedereschach

Phone +49 7728 64485-0  
[info@stein-automation.de](mailto:info@stein-automation.de)  
[www.stein-automation.de](http://www.stein-automation.de)

**STEIN Automation ITALY**  
Bologna

Phone +39 335 640 6900  
[italy@stein-automation.com](mailto:italy@stein-automation.com)  
[www.stein-automation.de](http://www.stein-automation.de)

**STEIN Automation NORTH AMERICA**  
Pittsburgh

Phone +1 724-554-2020  
[northamerica@stein-automation.com](mailto:northamerica@stein-automation.com)  
[www.stein-automation.de](http://www.stein-automation.de)